

# TRAY SEALERS

Models | TS-15 | TS-30 | TS-70-2 | TS-70-3

## VERSATILITY

The tray sealer is used not only for food products but also for industrial and medical supply packaging.

## FLEXIBILITY

These machines can be adapted to any size of tray.

## HIGH-PERFORMANCE

Automatic tray sealers come with a modified atmosphere packaging (MAP) system enabling them to preserve the freshness and colour of food products for long periods of time.

## EASY MAINTENANCE

Heavy-duty, reliable stainless steel and easily dismantled components ensure the best possible maintenance processes.

## WHY SHOULD YOU USE A TRAY SEALER ?

- 1 To avoid crushing delicate food items;
- 2 To preserve freshness;
- 3 To increase the shelf life of food products;
- 4 To prevent dehydration;
- 5 For easier handling;
- 6 To slow oxidation;
- 7 To protect against external contamination.



## MODEL TS-15 / MANUAL

<b>MACHINE DIMENSIONS</b>	<b>Length</b>	<b>A</b>	16" (408 mm)
	<b>Width</b>	<b>B</b>	25.5" (749 mm)
	<b>Height</b>	<b>C</b>	22" (550 mm)
<b>PRODUCTION CAPACITY</b>	5 cycles / min. (without vacuum)		
<b>MAX. DIMENSIONS OF TRAYS</b>	<b>Length</b>	<b>A</b>	10.3" (262 mm)
	<b>Width</b>	<b>B</b>	8.25" (210 mm)
	<b>Height</b>	<b>C</b>	5.3" (135 mm)
<b>POWER SUPPLY</b>	120 V / 1 pH / 60 Hz		
<b>PUMP CAPACITY (STD)</b>	N.A		
<b>MAX. FILM WIDTH</b>	10.75" / 275 mm		

# TRAY SEALERS

Models | TS-15 | TS-30 | TS-70-2 | TS-70-3



## MODEL TS-30 / SEMI-AUTOMATIC

<b>MACHINE DIMENSIONS</b>	<b>Length</b>	<b>A</b>	33" (834 mm)
	<b>Width</b>	<b>B</b>	43" (1,105 mm)
	<b>Height</b>	<b>C</b>	63" (1,605 mm)
<b>PRODUCTION CAPACITY</b>	2-3 cycles / min. (MAP)		
<b>MAX. DIMENSIONS OF TRAYS</b>	<b>Length</b>	<b>A</b>	13.9" (353 mm)
	<b>Width</b>	<b>B</b>	11.2" (284 mm)
	<b>Height</b>	<b>C</b>	4.5" (114 mm)
<b>POWER SUPPLY</b>	220-208 V / 3 pH / 60 Hz		
<b>PUMP CAPACITY (STD)</b>	40 m <sup>3</sup> 2.0 HP		
<b>MAX. FILM WIDTH</b>	19.5" (495 mm)		
<b>MICROPROCESSOR</b>	Touch Screen		

MACHINE DIMENSIONS

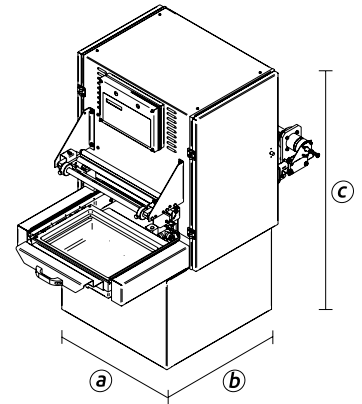

## MODELS TS-70-2 AND TS-70-3 / AUTO

		<b>TS-70-2</b>	<b>TS-70-3</b>
<b>MACHINE DIMENSIONS</b>	<b>Length</b>	<b>A</b> 150" (3,812 mm)	150" (3,812 mm)
	<b>Width</b>	<b>B</b> 45.7" / 1,162 mm	53.8" / 1,367 mm
	<b>Height</b>	<b>C</b> 80" (2,033 mm)	80" (2,033 mm)
<b>PRODUCTION CAPACITY</b>		5.5 cycles / min. (MAP)	5.5 cycles / min. (MAP)
<b>MAX. DIMENSIONS OF TRAYS</b>	<b>Length</b>	<b>A</b> 2X	3X
	<b>Width</b>	<b>B</b> 11.8" / 300 mm	11.8" / 300 mm
	<b>Height</b>	<b>C</b> 46.8" / 172 mm	6.8" / 172 mm
<b>POWER SUPPLY</b>	220-208 V / 3 pH / 60 Hz		220-208 V / 3 pH / 60 Hz
<b>PUMP CAPACITY (STD)</b>	305 m <sup>3</sup> 12.0 HP		305 m <sup>3</sup> 12.0 HP
<b>MAX. FILM WIDTH</b>	17.6" / 449 mm		25.7" / 654 mm
<b>MICROPROCESSOR</b>	Touch Screen		Touch Screen

# TRAY SEALERS

Models | TS-15 | TS-30 | TS-70-2 | TS-70-3



## BASIC FEATURES

### Model TS-15

- Certification CSA
- Tooling (first tooling)

### Model TS-30

- MAP – modified atmosphere packaging or sealing only
- Fast heating of tooling and electronic control of temperature
- Automatic film sealing and cutting mechanism for trays
- Automatic trim rewinder
- Teflon coated heating plate
- Fast tooling changes (no special tool required)
- Vacuum sensor
- Stainless steel adjustable legs
- Crate
- Certification CSA

### Model TS-70 (all models)

- MAP – modified atmosphere packaging or sealing only
- Fast heating of tooling and electronic control of temperature
- Automatic film sealing and cutting mechanism for trays
- Automatic trim rewinder
- Teflon coated heating plate
- Fast tooling changes (no special tool required)
- Vacuum sensor
- Output conveyor in 2 or 3 lanes
- Trays sensors (in and out)
- IP65 electrical cabinet including pneumatic enclosure
- Access panel with electronic interlock
- Gas tank
- Easy to clean conveyor
- Stainless steel adjustable legs
- Crate
- Certification CSA

## OPTIONAL FEATURES

### Model TS-15

- Tooling (extra)

### Model TS-30

- Dies (tooling) with cutting knives and filler chamber
- Cooling system for shrinkable film application
- Vacuum pump sizes
- Oxygen vacuum pumps for MAP with 21% of more oxygen mixed
- Gas tank
- Silencer
- Other voltages available
- Heated control box for microprocessor
- Service kit for standard maintenance

### Model TS-70 (all models)

- Dies (tooling) with cutting knives and filler chamber
- Cooling system for shrinkable film application
- Vacuum pump sizes
- Oxygen vacuum pumps for MAP with 21% of more oxygen mixed
- Booster pump
- Pre-printed film synchronisation
- Inkjet printing
- Thermal printing
- Merging conveyor
- Tray denester
- Silencer
- Other voltages available
- Heated control box for microprocessor
- Service kit for standard maintenance

*All features are subject to change without notice.*